

blokart[®]

OWNERS MANUAL



A word from inventor Paul Beckett:

Your new Blokart will give you, your family and friends hours of fun...zero emissions fun!

I would like to take this opportunity to welcome you to the Blokart family, which extends across the globe. You and thousands of owners are opening up a new world of friendship and competition both nationally and internationally.

Whether you are into competitive sailing or just 'blasting' with your friends - Blokart sailing has to be the best fun on wheels.



*Enjoy the ride.
Paul Beckett*

CONTENT

- 1 Introduction..... 4
- 2 Warnings 5
- 3 Checklist 7
- 4 Assembly 8
- 5 How to sail - Time to buckle up!..... 13
- 6 Into the bag 16
- 7 Where to go..... 19
- 8 Tips and terms..... 23
- 9 Smooth Running..... 26
- 10 Parts Diagram 29
- 11 Blokart Warranty..... 31
- 12. Register your Blokart with Global tracking 32

1 INTRODUCTION

Welcome to the exciting world of Blokart landsailing!

Blokart International Limited is dedicated to excellence in the design, manufacture and operation of the Blokart range. Every aspect of the Blokart has been carefully tested to ensure it gives you maximum enjoyment and performance.

Before using your Blokart for the first time, ensure you thoroughly read the owner's manual and view the [support videos](#) on our website.

The official Blokart website www.blokart.com is regularly updated with sailing locations, product information, dealer contacts and support documents.

Check it out when you are online!

To meet other Blokart users, share experiences, venues, tips, etc. be sure to go to our [Facebook page](#) or visit us on [Instagram](#).

Security

Each Blokart has its own unique serial number stamped on the chassis backrest bracket (on the chassis axle tube on older models). Record this number and retain your proof of purchase receipt for future reference.

2 WARNINGS

Blokarts are about serious fun... without causing serious harm!

As Blokarts are a high-performance sporting product there are a number of safety issues to consider before using.

- **BE CONSIDERATE**– Blokart sailing is a high risk sport and can be dangerous. Always exercise extreme caution when karting as improper use can cause property damage, serious injury or even death.
- **USE YOUR HEAD** – due to inherent risks involved in karting, no warranty of any kind is made or implied against accident, bodily injury or death, other than those which can be excluded by law.
- **BE RESPECTFUL** – you are responsible for the safe operation of the Blokart and the safety of others around you when karting.
- **BE RESPONSIBLE** – Blokart International Ltd will accept no liability for injury or damage as a result of using Blokarts.
- **BUCKLE UP** – always use the safety belt, leg restraining straps, helmet, gloves, shoes and eye protection at all times.
- **DO YOUR MAINTENANCE** – check the components of your Blokart before, during and after use to ensure parts have not become loose, worn or damaged.
- **CAN YOU STOP IT!** – as Blokarts do not have brakes it is important to make sure that you have enough area to stop or turn.
- **DON'T WALK AWAY** – do not leave your rigged Blokart unattended without laying it on its side to save it sailing away on its own.
- **HOW'S YOUR FITNESS** – only use a Blokart if you are in good health. Do not use a Blokart during pregnancy.
- **ARE YOU GOOD ENOUGH?** – do not use a Blokart in high or excessive winds. Sail within your ability.
- **PRACTICE MAKES PERFECT** – Always learn to sail in light winds. Only venture into stronger winds when you are able to control your speed and have developed the necessary techniques to stop in an emergency.
- **LOOK OUT!** – do not use a Blokart in thunderstorm or lightning conditions. Do not use a Blokart within 10 metres (33 feet) of other people, trees, obstacles, recreational equipment, power lines, structures or cars. Always allow plenty of space when passing as Blokart axles and wheels are wide apart.

- **GOT IT SORTED?** - If you find yourself with one wheel in the air, let out the sheet rope quickly to ease off the wind pressure in the sail and return all three wheels to the ground.
- **UHOH!** - If you accidentally flip the Blokart over, make sure you let go of the sheet rope, hold on to the handlebar with both hands and keep your feet inside the leg restraining straps or Pod until you come to a halt. Never put your hands or feet out of the Blokart until it has come to a complete stop.
- **ARE YOU SAFE AND LOOKING OUT FOR OTHERS?**
 - Make sure you have permission to use the area you have selected.
 - Obey all regulations for the area you have selected.
 - Always thoroughly check the area you intend to use, in particular look for holes, uneven ground, and any potential obstacles.
 - Do not use a Blokart in populated areas where people may be walking or playing.
- **READ THE INSTRUCTIONS** - Do not let anyone use your Blokart until they have read and fully understood the owner's manual and have been given tuition in light winds by an experienced person.
- **DON'T SNEAK UP ON PEOPLE** - Blokarts can be fast but quiet at the same time. With this in mind keep a look out for people, especially children who might be unaware of your presence.

3 CHECKLIST

Carry out the following safety checks every time you assemble and disassemble the Blokart.

- Check the kart (chassis, backrest, fork and keel tube, mast base, side struts and handlebar) for bends and all weld points for cracks or fractures.
- Check all nuts and bolts are tight – especially struts, belt and seat back.
- Check the safety belt and leg restraining straps are secure and intact.
- Check the seat seams for any wear and tear.
- Check that the fork pivots freely in the fork bushes.
- Check all quick-release clamps and spring buttons are operating correctly.
- Check all wheels turn freely, tyres are not excessively worn and wheel rims are free of fractures.
- Check all fibreglass components (axles, pulley whip, mast sections, boom and battens) for any cracks, fractures, or wear and tear.
- Ensure the mast bottom section always has a plug fitted.
- Check the sail for any damage.
- Check all ropes and pulleys run freely and are not excessively worn.

This ongoing checking and maintenance should help to ensure your Blokart retains the high safety standards with which it has been manufactured and continues to give you maximum enjoyment and performance.

Always replace worn or damaged components with official Blokart components immediately.

If you have any questions, please contact your local dealer for help and advice.

4 ASSEMBLY

Follow these instructions carefully to assemble your Blokart correctly. Be sure to carry out all the recommended safety checks in the checklist (section 3) as you assemble the Blokart.

Assembling the kart

1. Find a safe location to set up the Blokart i.e. no overhead power lines or trees etc.
2. Lay the bag on the ground with the narrow end pointing into the wind.
N.B. To work out the wind direction, throw some grass or sand up in the air and note the direction it blows from.
3. Unzip the bag fully and remove the loose contents (sail bag, fork and keel tube, rear wheels, handle bar and axles) leaving the chassis in the bag.
4. Attach a rear wheel axle stub into the fibreglass axle to one of the axles and secure in place with the spring button. Now lift one side of the chassis slightly out of the bag and slide the axle into the rear chassis opening. Ensure the spring button is in the axle alignment hole. Repeat for the other side.
5. You will notice a lanyard is clipped onto the spring button on one side of the backrest. Attach the other end of the lanyard to the other spring button. (The lanyard is disconnected to allow room for the rear wheels to pack into the bag when first shipped) Lift/pull the lanyard and pull the backrest fully back and then release for the spring buttons to click into place. Make sure that the spring buttons push through completely.
6. Lift up the mast base until it is near vertical and undo the two tri-knobs (it may be necessary to slide the leg restraining straps forward on the footbar to allow the mast base to stand vertical). Raise each of the side struts up, attach on to the mast base stud and firmly secure in place with the tri-knobs. Now push the tri-knob safety clip into one of the small holes in the other tri-knob to ensure it does not unscrew.
7. Loosen the Keel Tube quick-release clamp at the front of the chassis, raise the chassis front out of the bag then slide the fork and keel tube into the chassis until

the outer keel tube bush is located. Rotate the keel tube until the spring button clicks into place.

N.B. Do not tighten the keel tube quick-release clamp yet.

8. Loosen the quick-release clamp on the fork collar, and then slide the handle bar through the hole in the mast base and into the fork until the spring button clicks into place. Tighten the collar quick-release clamp to secure the handle bar in place. Now tighten the Keel Tube quick-release clamp at the front of the chassis.
9. Finally, slide out the bag from under your Blokart and store it securely so that it doesn't blow away.

N.B. To avoid corrosion do not expose the bag to salt water



Sail selection

Use this sail guide to help calculate the ideal sail size for the conditions and sailor weight.

		Wind In Strength						
		3	5	10	15	20	25	30
Body Weight	30 kg	5.5	4.0	3.0	3.0			
	40	5.5	4.0	3.0	3.0	2.0		
	50	5.5	4.0	4.0	3.0	2.0	2.0	
	60	5.5	4.0	4.0	4.0	3.0	2.0	
	70	5.5	5.5	4.0	4.0	3.0	2.0	
	80	5.5	5.5	4.0	4.0	3.0	3.0	2.0
	90	5.5	5.5	5.5	4.0	4.0	3.0	2.0
	100		5.5	5.5	4.0	4.0	3.0	2.0

Rigging the sail

1. Take the sail (including two battens, pulley whip, sheet rope, and front boom section) out of the sail bag (Note: the sail bag can be stored in the Blokart bag but requires folding the rolling, which can leave a permanent crease in the sail). Roll the sail out flat on the ground with the head/top of the sail facing downwind and insert any battens not already in the sail.
2. Loop both batten bungees over each batten end to provide tension to the batten N.B. Batten tension can be tuned by looping one bungee over the batten end for light wind sailing and two for stronger wind. See Tips and Terms (section 8) for adjusting batten tension.
3. Lay out the mast sections and starting with the tip section of the mast, (smallest diameter) slide into the mast sleeve, connect the number 2 section as you slide the mast into the sleeve, then the appropriate 3rd sections for the sail size (0 for a 2m, 1 for a 3m, 2 for a 4m & 3 for a 5.5m sail) and lastly insert the butt into the mast sleeve.
4. Fit the turban to the mast tip when the top of the mast appears through the top of the sail. You are ready to step the mast.

#Accessory Tip: replace the turban with a Blokart Mast Crane which allows the sail to pivot freely even in very light wind while under high downhaul loads.
N.B. The rigging procedure is the same for all sail sizes.



#Accessory Tip: Experienced sailors can replace the lower fibreglass mast sections with stiffer Ultra Carbon 900 Mast sections for improved performance but using these options makes the kart less forgiving (will tip easier) so good reactions are required. Talk to your dealer about the mast configurations suitable for your body weight and purpose.

N.B. When using the 5.5m sail, use Ultra Carbon lower mast sections for the best performance.

5. Insert the front boom section into the boom pocket at the front of the sail, slide it through and connect it into the rear boom section that remains in the sail.
N.B. Failing to insert the front boom section inside the boom pocket may cause damage to the mast when in use.
6. Tilt the boom upwards to 45 degrees to allow the gooseneck ('Y' shape fitting plugged into the front boom section) to locate onto the mast, and then bring it back down to rest against the back of the mast. The goose neck will slide up or down mast depending on downhaul tension.
N.B. See smooth running (section 9) for adjusting the boom tension.
7. Before stepping the mast into steel mast base of the kart, ensure it is clean. With kart facing into wind lift the assembled rig by the mast with both hands and place the mast bottom it into the mast base. Ensure the mast is fully seated in the mast base. Take care rigging, especially in strong winds.
8. With the Blokart facing into the wind, attach the hook of the downhaul cleat to the eyelet at the bottom (tack) of the sail. Make sure the cleat is facing toward the back, the braid is not crossed up or tangled and pull plastic bead to tension the sail. The integrated downhaul cleat will automatically lock and hold the tension set in the sail. Place the excess down haul rope and plastic bead in the mesh pocket.
N.B. Downhaul the sail until the mast is slightly bent and the battens are sitting off the mast. In general apply more downhaul tension when sailing in stronger winds and less in light winds.
9. Make sure the sheet rope and pulley whip are free running and not twisted, then plug the pulley whip into the backrest locating the spring button in place.

10. Check that the sheet rope is threaded through all three guides on the bottom of the sail, and then pass the remaining sheet rope through the pulley attached to the mast base.

#Accessory Tip: This pulley can be replaced with a ratchet block which requires less grip on the sheet rope, allowing you to sail longer.



N.B. Tying a knot in the end of the sheet rope or tying it to a strut is recommended to stop it pulling back out of the Blokart (pulley). But doing so risks catching the knot or loop of sheet on an object protruding the sailing surface, which could result in damage and/or injury. You have the option of not knotting or tying-off the rope but you will need to be vigilant that the sheet does not pull out of the block (pulley) allowing the sail to rotate 360 degrees which will result in damage to the sail.

N.B. Always keep ropes on board while sailing.

11. Now that you have successfully assembled the Blokart and completed the safety checks (section 3), you are almost ready to go.

Next time, assembly should only take 5 minutes!



5 HOW TO SAIL - TIME TO BUCKLE UP!

1. First turn the Blokart slightly away from the wind so that the sail moves to the downwind side to allow easy access.
2. Standing at the upwind side of the Blokart, push the handle bar down and away from you to create more space. To get in, step over the side strut and place your foot onto the floor pan, then sit down in the seat. Keeping the handle bar to one side, bring your other leg over the side strut into the Blokart. Now slide right down so your butt almost touches the bar at the front of the seat, lie back and get comfortable.

#Accessory Tip: If you are tall, you will find a Blokart Footbar Extension or the extra length of a Blokart Pod helpful. Smaller people will find the Blokart Junior Footbar helpful to brace against.

3. Secure the safety belt across your chest/waist (you may have to adjust the length of the belt) and push the tongue into the buckle to lock.
Note: The buckle is released by lifting the tab on the top. Adjust your seat belt length by pulling the excess belt through the buckle. (Just like aeroplane seat belts).

Sailing Guidelines

Before setting off, there are four main rules to follow when sailing a Blokart to ensure it is an enjoyable experience.

Rule 1: Let the rope go to let the wheel come back down

- While sailing, one of the rear wheels can lift off the ground due to the wind pressure in the sail. If this happens **LET THE ROPE GO** or allow it to slide through your hand to drop the wind pressure out of the sail. This will bring the wheel back down to the ground.

Important: The rope should run below the handlebar to avoid interference with steering. Avoid wrapping it around your hand, to ensure you can release the rope.

Rule 2: Let the rope go so as not to capsize

- If the rear wheel is kept off the ground while the sail is full of pressure there is a strong possibility that the Blokart will capsize. As soon as you realise that you are tipping over **LET THE ROPE GO**.

Important: Hold on to the handle bar with both hands and allow the blokart to take the fall. Keep your hands on the handlebar and feet inside the Blokart until the kart comes to a stop.

Once the Blokart has stopped, support yourself, release the safety belt, climb out and right the kart.

Rule 3: Let the rope go to corner

- When approaching a corner at speed it is recommended that you **LET THE ROPE GO** and focus only on steering around the corner. Do not change your course when this happens, just concentrate on steering around the corner. Once your heart rate gets back to normal, re-gather the rope and fill your sail with more wind pressure to keep your momentum.

Rule 4: Let the rope go to stop

- To slow down gradually, **LET THE ROPE GO** and focus on pointing the Kart directly into the wind until it stops. The sail can be pushed out against the wind with your hand to act as a brake.

If you need to stop quickly, let the rope go (letting the rope run through the hand) and either turn the Blokart hard in either direction sliding the rear wheels to end-up pointing into the wind or by turning the kart into as many tight circles or 360's as is necessary to stop.

Important: Keep your hands and feet inside the Blokart until the kart rolls to a stop. **DO NOT** use your hands or feet to stop the Kart.

Important: Learn how to slow down and stop before trying to break the speed record!

Accessory Tip: The Blokart Disc Brake is recommended, especially if sailing in a confined area. For more stopping tips see tips and terms (section 8).

Wind Direction

Ensure you are familiar with the wind direction and note that Blokarts cannot sail directly into the wind. A basic explanation for first-timers: If the wind is coming from 12 o'clock then you cannot sail when pointing in the 11am to 1pm zone. The more you turn away from the wind the easier/faster you will sail.

Lets go sailing!

When you have fitted your safety belt and you're ready to go, put your feet inside the leg restraining straps and rest them on the front foot bar. Tuck your knees inside the side.

Turn the Blokart across the wind, pull the sheet rope in slowly to power-up the sail and hold with one hand while steering the handlebar with the other!

N.B. For sailing tips see tips and terms (section 8).

Physically Impaired Sailors

One of the great things about Blokart is that almost anyone can use them, literally one size fits all!

There is no need to make changes to accommodate different users, and that includes many people with physical disabilities or limited mobility. The ingenious design of a Blokart makes it accessible even directly from a wheel chair;

With the Blokart fully assembled, facing into the wind simply disconnect one of the side struts from the mast base and lower it down flat. This allows people to manoeuvre themselves from their wheel chair into Kart. The side strut can then be easily raised and secured in position.

Accessory Tip: A Blokart Harness and additional tailored straps can be used to secure the user in place while sailing.



6 INTO THE BAG

Please follow these instructions carefully in order to pack down your Blokart correctly.

Remember to carry out all the recommended safety checks under check list (section 3) when disassembling.

If your Blokart has been used on a beach or near salt, always wash it down with fresh water when you have finished. Make sure your Blokart is dry and clean and all moving or sliding components have been lubricated before packing it in the bag.

Disassembling the sail

1. Point the Blokart into the wind so that it doesn't blow away.
2. Disconnect the pulley whip from the backrest, but leave the sheet rope threaded through the pulley whip and all of the guides.
3. Untie the knot in the end of the sheet rope and pull it out of the mast base pulley.
4. Remove the downhaul rope and plastic bead from the sail mesh pocket and release the sail tension. Remove the integrated downhaul cleat from the eyelet at the bottom of the sail.
5. Reverse the assembly process to disassemble. Alternatively, having already done steps 2 & 3: lay kart on its side, facing into the wind with mast in, remove turban or mast crane and pull sail off mast, rolling as you go, this does two things, keeps the sail off the dirt or wet ground and holds the together and slips out complete. Stand kart up and remove mast sections (roll the sail from the top to the bottom so all hardware is accessible when rolled.
N.B. After initial assembly battens and boom can remain rolled in the sail (except 5.5m, top two taken out and tucked into rear of boom pocket).
6. All ropes and battens roll into the sail for ease of set up next time.

The team at Blokart encourages users to store sails fully rigged and rolled into sail bags whenever possible.

Disassembling the kart

1. Slide the opened Blokart bag under the chassis of the assembled kart and pull out the Keel Tube Bag and the protective flap.
2. Pull the lanyard between the backrest spring buttons to release the spring buttons (if the spring buttons don't release you may need to pull the backrest back to ease the tension first), push the backrest forward to the centre of the Blokart.
3. Remove the rear axles and wheels from the chassis and drop the rear of the chassis straight down into the bag. Disconnect the axles from the wheels and stow the axles along the rear of the bag.
4. Loosen the fork quick-release clamp, press down the handle bar spring button and remove the handle bar out through the mast base.
5. Loosen the keel tube quick-release clamp, press down the keel tube spring button, and pull out the fork and keel tube from the main chassis. Drop the chassis fully into the bag.
6. Remove the Mast base tri-knobs and drop the side struts down flat. Replace the tri-knobs.
7. Push the backrest down flat followed by the mast base.
IMPORTANT NOTE: Fold the protective flap over the seat before packing the wheels to prevent the wheels damaging your seat.
8. Please pay particular attention to the order and positioning of components in these final steps.
9. Standing at the rear of the bag, place one wheel on the rear left hand side of the bag with the stub-axle pointing up.
10. Insert the fork and keel tube into its protective bag and place down the right hand side of the main bag with the wheel towards the front and the fork facing down.
11. Slide the small protective sock (attached by rope to the inside of the bag) over the front end of the handle bar (so it does not scratch the floor) and place down the centre of the bag.
12. Place the remaining wheel on the rear right hand side of the bag with the stub-axle pointing down.
13. If you want to fit the sail in the Blokart bag, lay the sail bag on the left hand side of the bag, bend the top of the battens to one side and zip up the Blokart bag.
N.B We recommend long rolling the sail and storing/transporting it in its sail bag as repeat folding then rolling will result in a number of permanent creases up the sail.



Wheeling the bag

Two axle spacers (Slugs) are included in the zipped pocket of the Blokart bag to allow you to attach the wheels directly to the bag. These are great for wheeling the bag around airports, down to the beach etc.

To fit the axle spacers, slip over the stub axles on the wheels. Slide the axles through the holes in the side of the bag and into the chassis locating the spring buttons.

Wheel the bag using the handle at the front like a golf trundler.

N.B. Always remove the wheels and put them back inside the bag to ensure the wheels and stub axles are not damaged in transit.

7 WHERE TO GO

With a little wind your Blokart can be used on just about any firm, flat surface that is free of obstacles. As Blokarts are very manoeuvrable, you only need a small area to have a lot of fun. Ideal locations include the beach, empty parking lots, sports and recreation fields and airfields.

These areas are often public places so it is very important to consider the safety of others. Do not sail within 10 metres (33 feet) of other people, power lines, structures or cars.

Ensure you thoroughly read and understand the Warning Section.

Beaches

Blokarts are a lot of fun on the beach. Most beaches and dunes however are important habitats for unique plant and animal life, so as a general rule, always sail below the high tide mark to eliminate any damage. In any case, sand above the high water mark is usually too soft for good Blokart sailing.



Accessory Tip: To lengthen the life of wheel bearings, fit a set of Blokart Bearing Shields which protect your bearings from salt water and sand. Ideal also in the desert.

The Blokart Mudguard/Fender to minimise the sand spray from the front wheel is also a good idea.

Empty Parking Lots

Empty car parks are ideal for sailing especially if the wind is light. It is recommended to obtain permission before using these areas. Sealed surfaces demand concentration and skill due to the number of obstacles often found in them. The lack of friction in these areas can result in high speeds so take care and make sure you master the techniques of sailing, particularly how to slow down or stop on sealed surfaces.

Sport and recreation fields

Large grassy grounds are great in stronger winds, but once again, obtain permission. Remember that sport and recreation fields are generally aimed at team sports or passive recreation. Using sports and recreation fields for Blokart sailing should be considered a privilege, and not a right.

Blokart tyres will generally not harm turf with occasional use but repeated turning and sliding in the same area may scuff the surface and leave marks. When using a marker or flag as a turning point it is important to regularly move them around to prevent damage to the turf. However, Blokart sailing with friends will probably cause less damage to the turf than a game of football.

One Design

The Blokart is a One Design product, this means:

1. All Blokart components and accessories are compatible with each other.
2. Official Blokart racing is restricted to Blokarts only, no other land yachts can compete, and this means a level playing field for all racers.
3. Only Blokart products can be used for racing so the outcome is a matter of pilot skill rather than product performance. With a large range of accessories there are plenty of opportunities for Blokart owners to customise their kart to suit their needs.
4. One Design Blokart racing is very affordable. The capped design, zero running cost and minimal maintenance means racers can operate on a small budget. N.B. there are some generic parts that do not need to be from Blokart, e.g. pulley systems and ropes. See the [IBRA Rules](#).



Blokart Road Rules

The Blokart road rules have been put together to help minimise the risk of accidents and injury. Make sure you understand and use the following rules.

1. Always use the safety belt, leg restraining straps, helmet, gloves, stout shoes and eye protection at all times.
2. If you are travelling head-on towards another person, always steer to the right.
3. In general, always give way to your right. (ISAF sailing rules generally apply at Blokart regattas)
4. Keep well clear when overtaking or overlapping others.
5. Do not make any sudden moves or turns when you are being over taken.
6. Check behind you before making any changes in direction.
7. Use a hand signal if you intend to turn or stop.
8. When turning around a marker or flag, do not pass others on the inside or 'cut them off'.
9. Do not force others on to ground that is unsafe, into obstacles or other Blokarts.
10. If you need a push start, be aware of and don't get in the way of others that are moving.
11. Secure your Blokart safely when you're not using it by turning it over on its side or applying the hand brake if a Blokart disc brake is fitted.
12. Remove pulley whip so sail can weather cock and not power up (out of gear)

Give way

When two Blokarts are converging, the sailor which has the other on the right must give way. This may vary, some rules state windward kart keeps clear, so it depends on wind direction.



Head on

When two Blokarts are approaching each other head-on, each sailor must turn right.

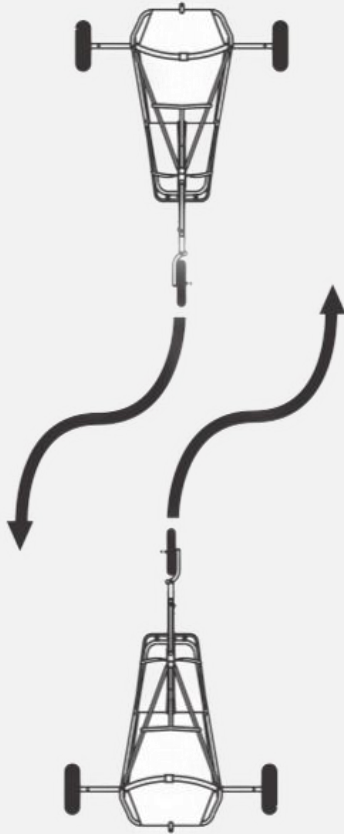

Overtaking

Keep well clear of the Blokart being over-taken, generally on the upwind side.

N.B. When sailing with others at an unfamiliar venue check with local sailors regarding their specific right of way rules.

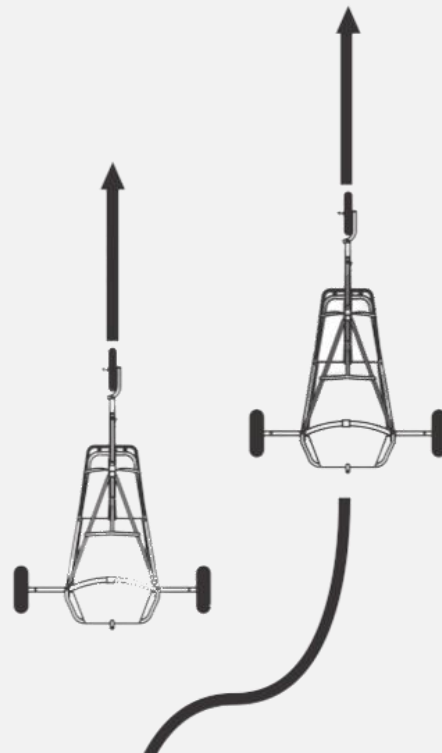

8 TIPS AND TERMS

Here's a bit of technical info to help you talk the talk!

Beam Reach (across the wind): Travelling at 90° to the wind direction. This is generally the fastest sailing angle.

Broad Reach: Travelling at up to 45° downwind off a beam reach. This too is a fast angle in which to sail.

Close Reach: (travelling upwind): Travelling at up to 45° toward the wind direction.

Close Haul: (on the wind): Travelling even higher upwind than a close reach. The Blokart can point up to 25° toward the wind before it stalls.

Travelling Downwind: Usually the slowest direction to travel in as you can only go as fast as the wind is blowing. Let the sail out far to one side to catch as much wind as possible. Better to sail angles where possible (broad reaching – see technical terms)

Tacking: Turning into the wind direction during a turn. Tacking is the best way to turn when learning as the Blokart slows down through the turn. Letting the sail out as you start to tack also helps to keep the Blokart stable in strong winds by reducing the wind pressure in the sail. Tacking is used when making your way upwind.

Warning: the wind resistance of a sail when tack-turning into strong wind can make the front wheel weightless and difficult to steer. Master your turning before sailing in strong wind.

Gybing: Turning away from the wind direction during a turn. Gybing is generally faster than tacking, as the sail remains powered up through the turn. Learn to gybe in light winds as a proper gybe takes practice. It is important to always pull the sail in as you turn away and when the wind is directly behind you. Then ease it out so that the sail does not move with excessive force from one tack to the other.

Warning: Failing to gybe correctly can result in product damage including the pulley whip breaking, sail tearing and/or broken downhaul components. This is not covered under the Blokart product warranty. Learn to gybe in light wind.

Capsizing: Using the correct sail to match the wind conditions can help ensure you remain on three wheels. If you find yourself with one wheel in the air, release the sheet rope quickly to ease off the wind pressure in the sail and to return all three wheels to the ground preventing a capsize.

If you flip the Blokart over, make sure you let go of the sheet rope, hold on to the handle bar with both hands and keep your feet inside the leg restraining straps until you come to a halt. Never put your hands or feet out of the Blokart until it has come to a complete stop.

Accessory Tip: Blokart Foiled Mast Sleeve Protectors help prevent sail damage and are a must when sailing on concrete or asphalt surfaces to protect valuable sails.

Stopping: Always learn to sail in light winds. Only venture into stronger winds when you are able to control your speed and can stop in an emergency. To slow down gradually, turn directly into the wind then push the sail out to one side with one hand to act as an air brake.

Turning in very tight circles can also be used to burn off speed and eventually slow down. If you need to stop quickly, turn the Blokart hard in either direction to spin it around and stop.

Accessory Tip: The Blokart Disc Brake is recommended, especially if sailing in a confined area. The Disc Brake also features a very handy parking brake.

Tuning: In strong winds the increased force of the wind on the sail causes the mast to bend and flex considerably which can result in a reduction in sail efficiency and speed.

Increasing the downhaul tension can counteract this. Experience and practice will enable you to judge the best downhaul tension. In general, more down-haul tension is required when sailing in strong winds and less in light winds. Batten tension can be tuned by looping one bungee over the batten end for light wind sailing and two for stronger wind. The knot in the bungee can be repositioned to increase or decrease the batten tension as required. Just ensure sufficient pressure so the bungee remains on the batten so it does not fall out. Warning: Never use a sail without a full set of battens.

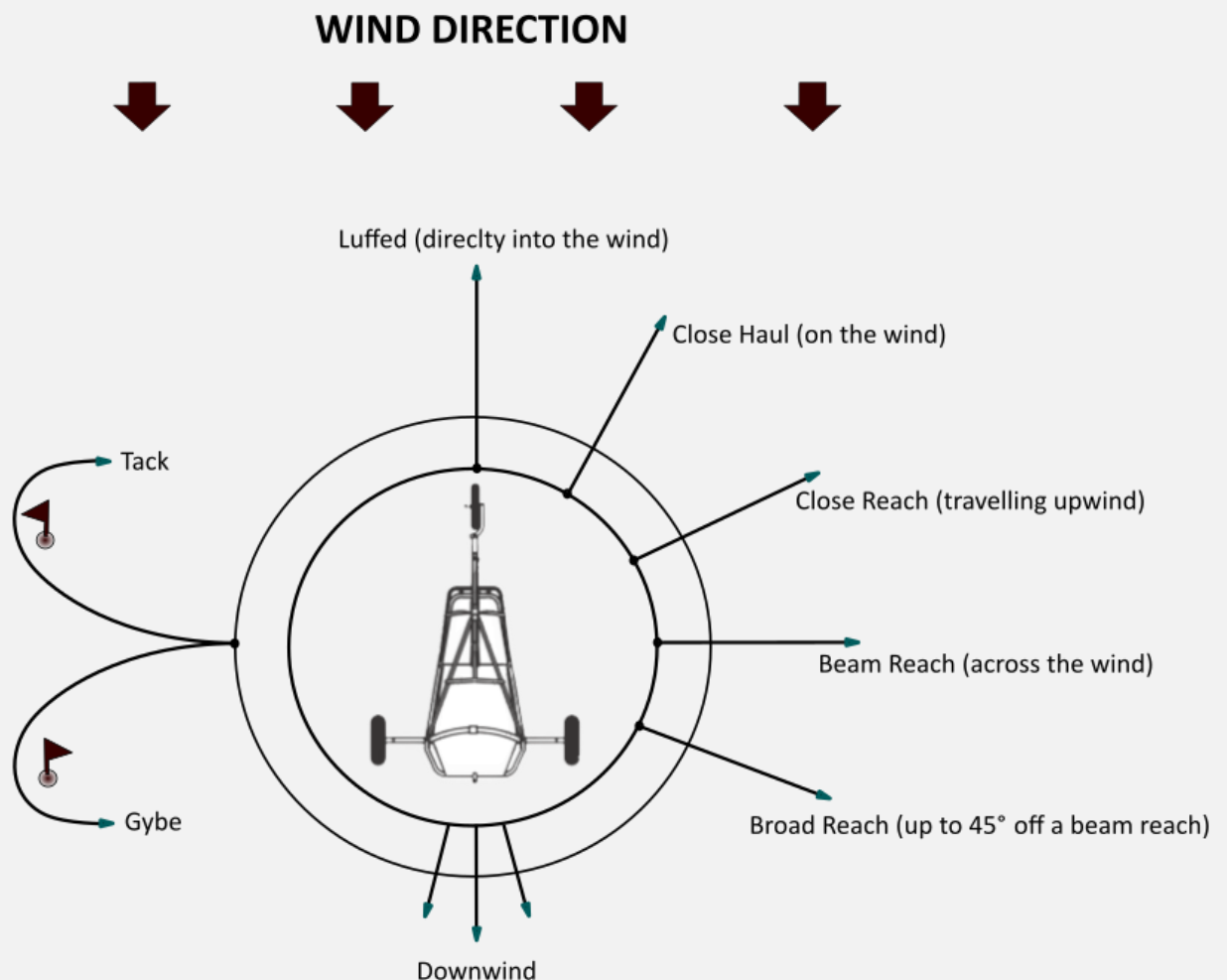

WIND DIRECTION

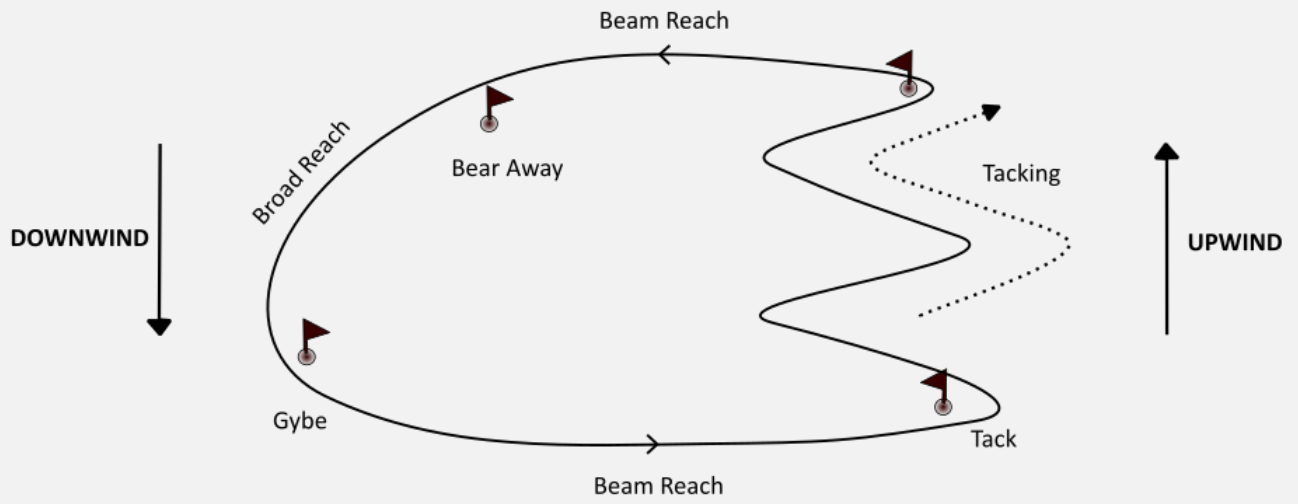
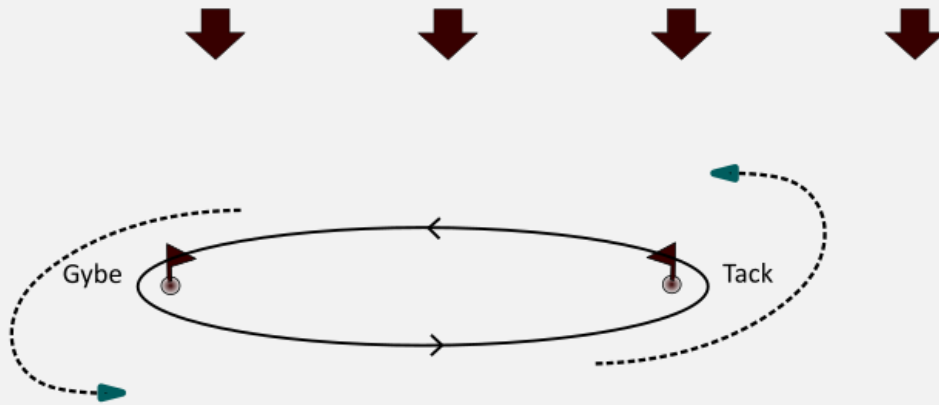

9 SMOOTH RUNNING

If your Blokart has been used on a beach or near salt water always wash it down with fresh water as soon as you have finished. Always make sure your Blokart is dry and clean and all moving or sliding components have been lubricated before packing it in the bag.

Side Struts: The side struts can bend to help absorb the impact transferred through the mast and mast base when you accidentally flip over. If you need to straighten the side struts leave the kart fully assembled, lay it on its side and with two hands spreading load, push/pull back straight.

Mast and Mast Base: Wipe down the mast sections and mast base to make sure there is no sand/grit that could lock them together making them difficult to separate.

Wheel Bearings: Although the wheel bearings are made of stainless steel, they still need regular maintenance in order to keep them in good condition. Always dry and spray a little lubricant on the exposed bearings after use.

It is also advantageous to periodically remove the bearings and replace the grease that is packed inside during manufacture.

To do this:

1. With the wheel removed insert a blunt punch into the hub on a slight angle so it connects with the inside of the opposite bearing. Lightly tap it out with a mallet.
2. Remove the rubber dust shields (black ring) on each side of the bearing by levering it out with a fine tool. Be careful not to damage it.
3. Flush the bearing with a degreaser and then dry thoroughly.
4. Repack with suitable grease.
N.B. a light lubricant will allow the wheel to roll faster but will require frequent maintenance.
5. Carefully clip the dust shield back in place.
N.B. leave off the inside dust shields to reduce the wheel friction so the wheel can roll
6. Press the bearing back into the hub using a flat piece of wood over the bearing and lightly tap with a mallet until flush with the hub. Remember to fit the spacer between the bearings before pressing in the final bearing.
7. Locate the spacer with a screwdriver (or similar), slide in the stub axle and tighten the axle nut.
8. Lightly tap each end of the axle with a wood/nylon mallet to seat the bearing and re-tighten the axle.

Fork: Periodically remove the fork from the keel tube and clean and lubricate the contact surfaces to stop the steering squeaking or tightening up.

To do this:

1. Remove the R-clip from the fork-retaining pin and slide the pin out.
2. Pull the fork out from the keel tube.

3. Wipe the fork steering tube and the inside of the steering bushes with a clean cloth to remove any dirt. Lubricate the surfaces.
4. Check all components including axle and fasteners for any cracks and to ensure they are not working loose.
5. Refit the fork by reversing the process above.

Tyre Pressure: Always ensure the tyres are inflated to the correct pressure. Tyres that are too soft wear quicker and significantly reduce your speed when karting. Tyres that are overinflated puncture more easily, the crown wears off quicker and they are at greater risk of popping during use.

Tyres can be inflated to a maximum of 30psi Rear and 35psi Front, these numbers are printed on the wheel rims, however users may choose to vary the settings at their own risk.

N.B. Exceeding the recommended tyre pressure could blow the tyre off the rim which could result in damage to the rim, tube and tyre and injury.

Tyre Wear: Tyre wear varies greatly depending on the weight of the user, the type of surface being used, and speed and tightness of your turns. Hard surfaces such as asphalt or concrete will wear tyres out quicker than soft or loose surfaces such as sand or grass. Hard surfaces however make it easier to get going in light winds. Always replace a tyre as soon as the middle three treads are worn flat. Failure to do so could result in excessive punctures or tyres popping while in use.

N.B. Do not use your Blokart with badly worn tyres as a blown tyre could result in damage or injury.

Pulleywhip: Check for cracks regularly. The Pulleywhip is designed to be sacrificial in extreme circumstances if subjected to excessive force, usually the result of gybing incorrectly in strong winds.

N.B. Try not to push stationary karts by the Pulleywhip. Push on the Backrest.

Boom Tension: From time to time you may need to increase the boom tension of the sail in order to remove any vertical lines that appear in the sail. These will occur just above where the front and rear boom sections join. Incorrect boom tension reduces the efficiency of the sail.

To do this:

1. With the sail fully rigged, first release the downhaul tension.
2. Release the boom strap from its locked position in the ladder lock
3. Push the end of the boom in with one hand towards the front of the sail while pulling the strap back firmly towards you with the other hand until tight and the vertical lines in the sail have been removed. Do not over tighten.
4. Re-lock the strap back in place.

N.B. Always replace worn or damaged components with official Blokart components immediately.



Racing

With clubs and events being established all around the world Blokart racing is gaining momentum.

Racers compete in a range of weight divisions and in two categories, production which is straight out of the box, (see [IBRA rules](#) for alternatives) and performance, where competitors can use Blokart performance accessories.

Karters around the world are enjoying the fast, free-flowing sport.

10 PARTS DIAGRAM

1. Turban
2. Mast pocket
3. Mast
4. Batten pocket
5. Finger batten
6. Batten
7. Batten bungee
8. Performance batten loop
9. Boom pocket
10. Boom
11. Gooseneck
12. Mesh pocket
13. Adjuster key pocket
14. Eyelet
15. Integrated downhaul cleat
16. Sheet rope
17. Pulley whip
18. Chassis
19. Side strut
20. Foot bar
21. Mast base
22. Leg restraining strap
23. Mast base eye and pulley
24. Mast base bush
25. Tri-knobs

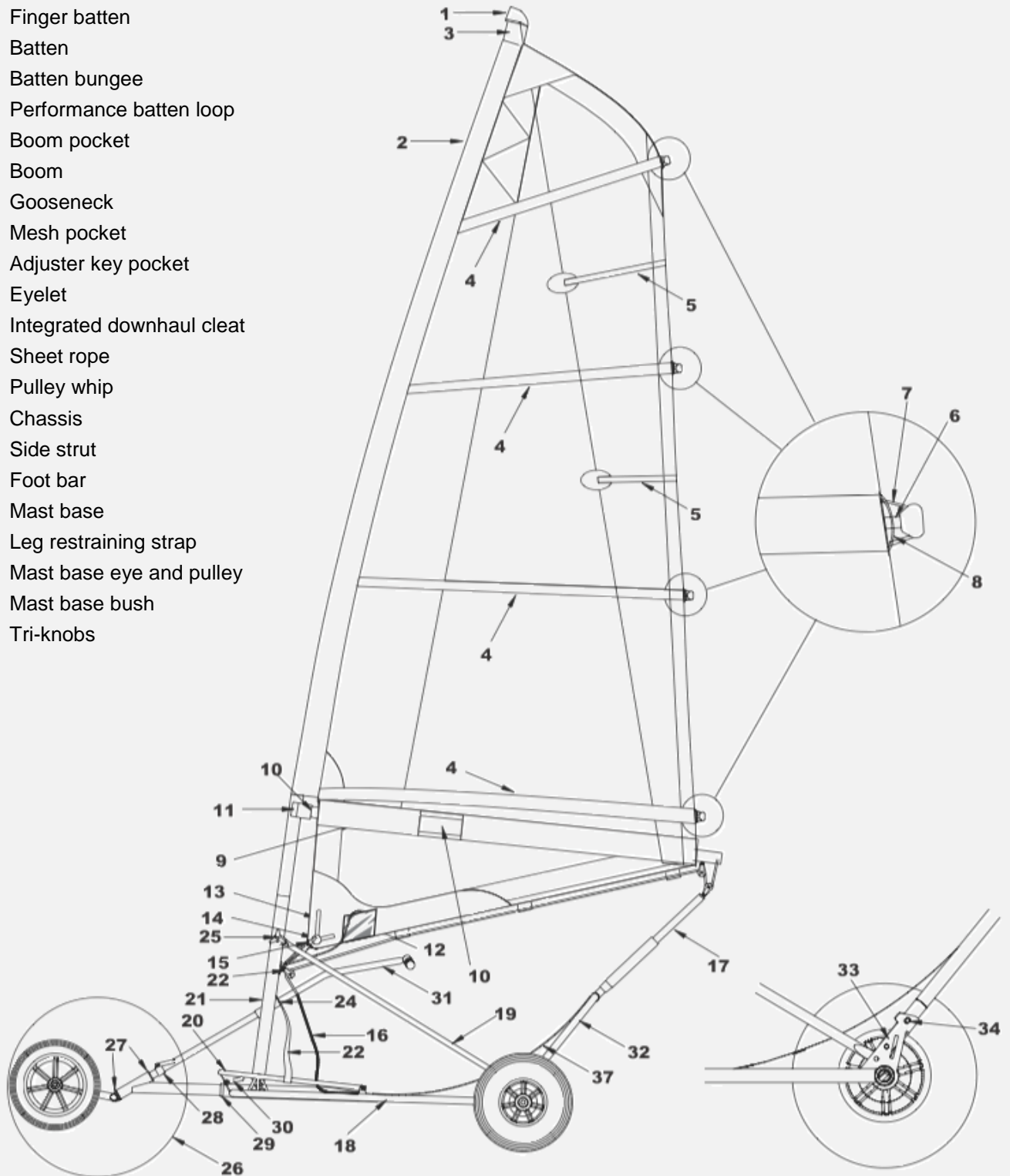

- 26. Fork and keel tube
- 27. Fork bush
- 28. Fork quick-release clamp
- 29. Outer keel tube bush
- 30. Keel tube quick-release clamp
- 31. Handle bar
- 32. Backrest
- 33. Backrest bracket
- 34. Backrest spring button
- 35. Axle
- 36. Spring button
- 37. Seat
- 38. Safety belt
- 39. Tongue and buckle
- 40. Floor pan

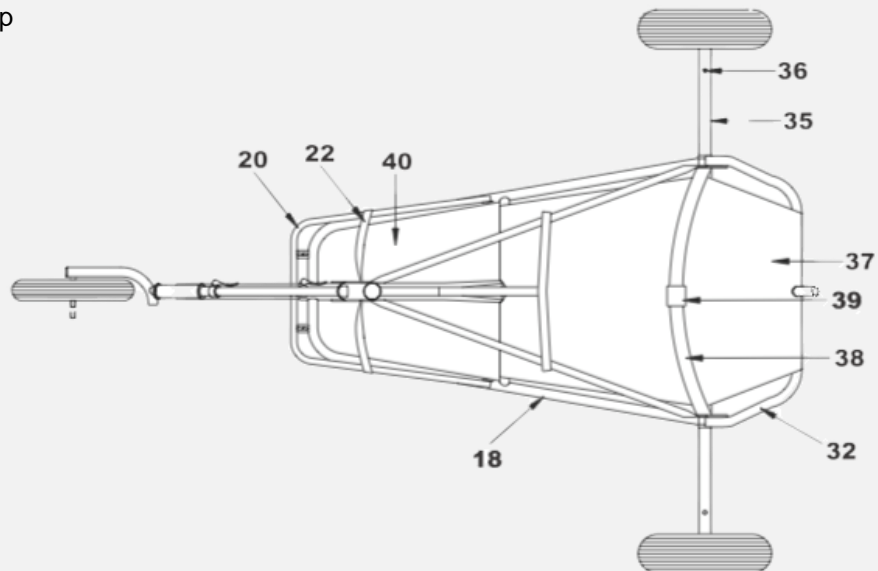

11 BLOKART WARRANTY

Blokart International Ltd warrants that all Blokart products are free of manufacturing defects in workmanship and materials and that Blokart International Ltd will repair or replace defective parts (excluding that caused by careless handling, accidents such as collisions, punctures, bearings and general wear and tear) for the period of 12 months from the date of purchase.

- Any damage caused as a result of an accident, flipping, jumping or sailing on unreasonably rough terrain is not covered under the Blokart warranty. It is the users responsibility to ensure that all three wheels of the Blokart remain on the ground at all times.
- Failure to sail within recommended wind strengths can result in damage which is not covered under the Blokart product warranty. For recommended sail size, see the sail chart (inside front cover).
N.B. Exceeding recommendations can cause property damage, serious injury or even death.
- Failing to gybe correctly can result in product damage including the pulley whip breaking, sail damage and/or broken downhaul components. This is not covered under the Blokart product warranty. For correct gybing technique see tips and terms (section 8).
- Using non-official Blokart components will invalidate the Blokart warranty.
- If you intend racing your Blokart see IBRA handbook for the One Design rules. You will find the link to IBRA in the support section of www.blokart.com

Claim Procedure

Contact your Blokart Dealer who will either require the faulty item to be returned or detailed photo's to be emailed along with the proof of purchase and details of the issue. The Dealer will process legitimate claims with Blokart International for replacement or repair.

Record your Blokart details for future reference

Model.....
Serial number (found on the rear of the chassis).....
Sail Size/s and Colour.....
Accessories.....
.....
.....
.....
.....
.....
Purchased from.....
Purchase Date.....

Note: retain your proof of purchase necessary for warranty claims

12. REGISTER YOUR BLOKART WITH GLOBAL TRACKING

Allow us to track the history of your Blokart by registering it with Blokart International Ltd.

Simply email the following details to service@blokart.com

- # Model
- # Serial number
- # Purchase Date
- # Purchased From
- # Full Name
- # City
- # Country
- # E-mail

Privacy: Blokart International Ltd respects the privacy of individuals who submit information tracking and research purposes. Your email address and/or other information will not be provided to any third party without your prior consent.

Blokart, the Blokart logo, the Blokart icon and the Blokart 1 Design logo are the exclusive property and registered trademarks of Blokart International Ltd. Only authorised use is permitted.

Blokart International Ltd, 5c Macdonald St, Mount Maunganui 3116, New Zealand
E: service@blokart.com W: www.blokart.com